

ASAHI KINZOKU Co.,Ltd

The pioneer of loading machine.

# Card Distributor

## MODEL CT-12T

Includes new improved mechanism!  
120pcs/min capacity has been achieved  
with a new servo design.

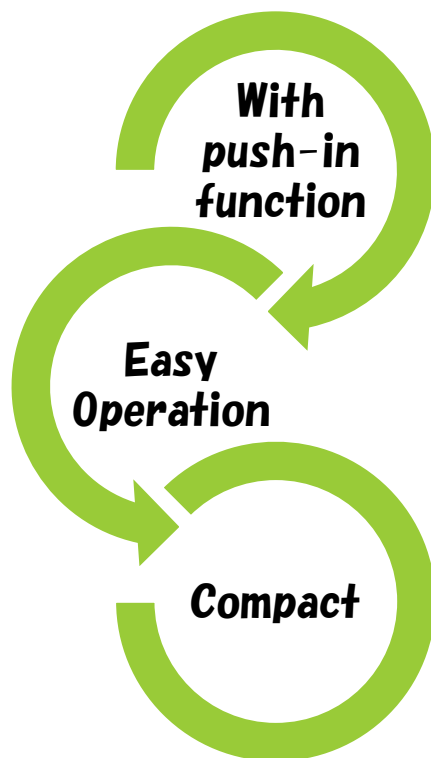

**For the following items**

- 'AGELESS' cards
- Desiccant sheet
- Collector's cards/Novelty cards
- Promotional stickers

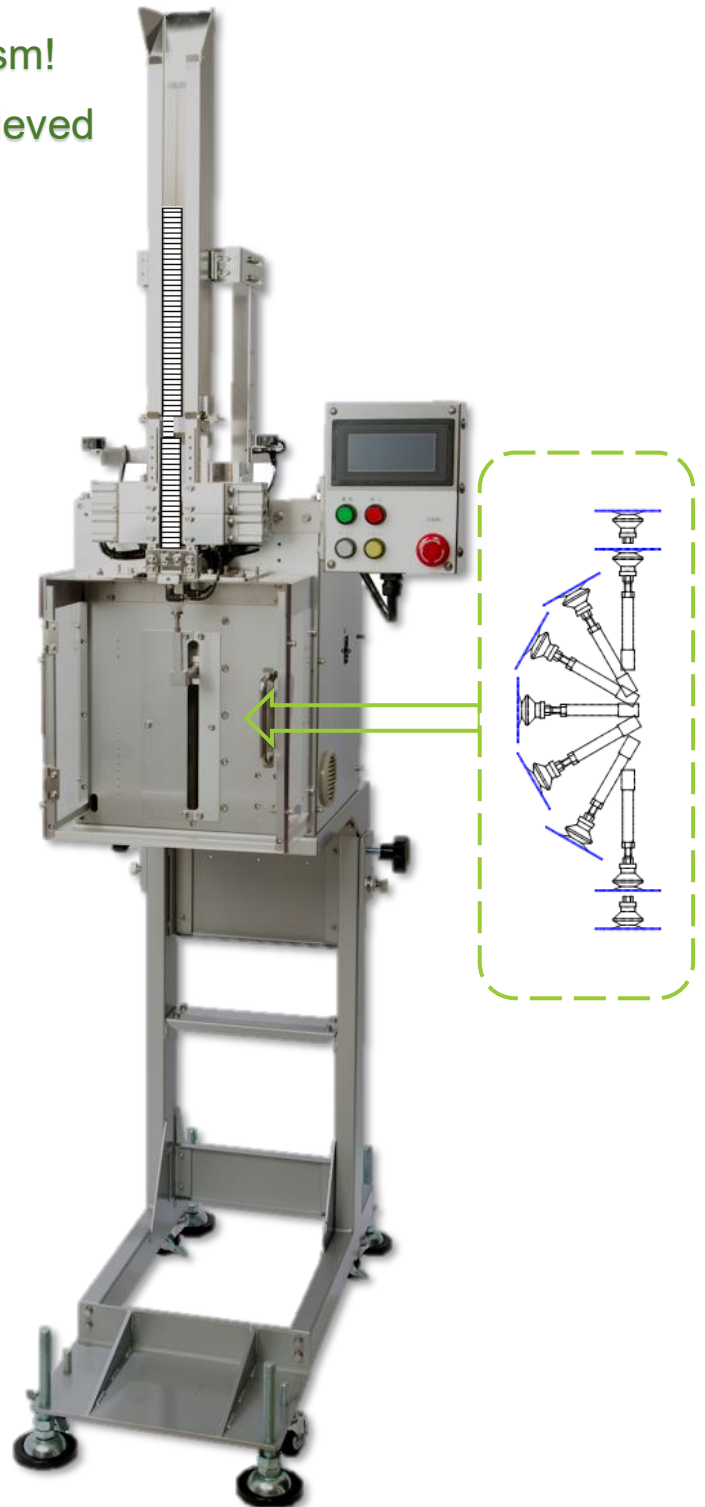

Our **CARD DISTRIBUTOR** is ideal for placing card type desiccants, stickers, 'AGELESS' cards and more on to the conveyor of a packing machine.

**CT-12T  
FEATURES**

- Compact, smooth and low noise operation due to inclusion of a servo design.
- High stability for safe operation.
- Easy to change cards with a cassette type feeder.

**SCHEMATIC  
DIAGRAM**

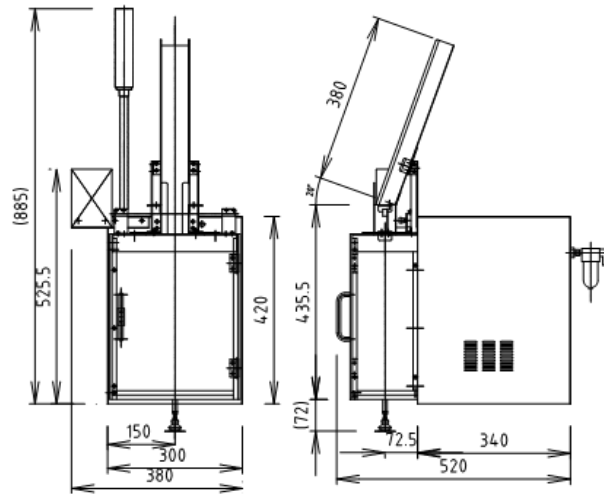

➤ It is possible to change the form of cassette or add devices according to the specification needs of the customer.

**STANDARD  
SPECIFICATIONS**

- Capacity:** 120pcs/min
- Card Size:** 30~100mm(W)×30~100mm(L)×MAX1mm(T)
- Dimensions:** 500mm(W)×539mm(H)×538mm(L)
- Power Supply:** AC200V 50/60Hz Single phase
- Air Pressure:** 0.5~0.6MPa
- Air Consumption:** 40Nℓ/min
- Power Consumption:** 800VA
- Machine Weight:** 35kg

**OPTIONAL  
DEVICES  
ARE AVAILABLE**

- **Automatic Cassette Changeover Device**
- **Signal Tower**   ● **Adjustable Stand**

- Please do not hesitate to contact ASAHI KINZOKU for expert advice about our new **Card Distributor**.
- Specifications and appearance are subject to change without notice. (because of improvements or updates).
- Additions or changes to the specifications can be arranged through consultation.



**CAUTION**

**For Safe Use**

- Read operation manual carefully before use for proper and correct operation
- Use the machine only with indicated electric current and voltage
- Be sure to ground the machine to prevent electrocution or short circuit.

**Sales &  
Manufacturing  
Headquarters**



505 Simomaruya-cho, Nishi-iru, Chiekoin-dori,  
Shimodachiuri-dori, Kamigyo-ku, Kyoto city  
602 - 8176 JAPAN  
Tel +81-75-801-0154 Fax +81-75-842-1351  
URL <http://www.akg.jp/kinzoku/>  
E-mail [asahi@akg.jp](mailto:asahi@akg.jp)

**Tokyo Sales Office**

10-2 Miyamoto-cho, Ageo city, Saitama Prefecture  
362-0036 JAPAN  
Tel +81-48-771-0662 Fax +81-48-773-5937

**Kyushu Sales Office**

No. 206 Ichikura Building, 1-26, 2-chome, Hakata  
station south, Hakata-ku, Fukuoka city 812-0016,  
JAPAN  
Tel +81-92-471-5234 Fax +81-92-473-7150

■ Reference