

ASAHI KINZOKU Co.,Ltd

The pioneer of loading machine.

Automatic Folding Device

X-ray Inspection Device

equipped

MODEL

ORA-600TK

60m/min

High-Speed

Storage

Jam and foreign object inspection system is incorporated.

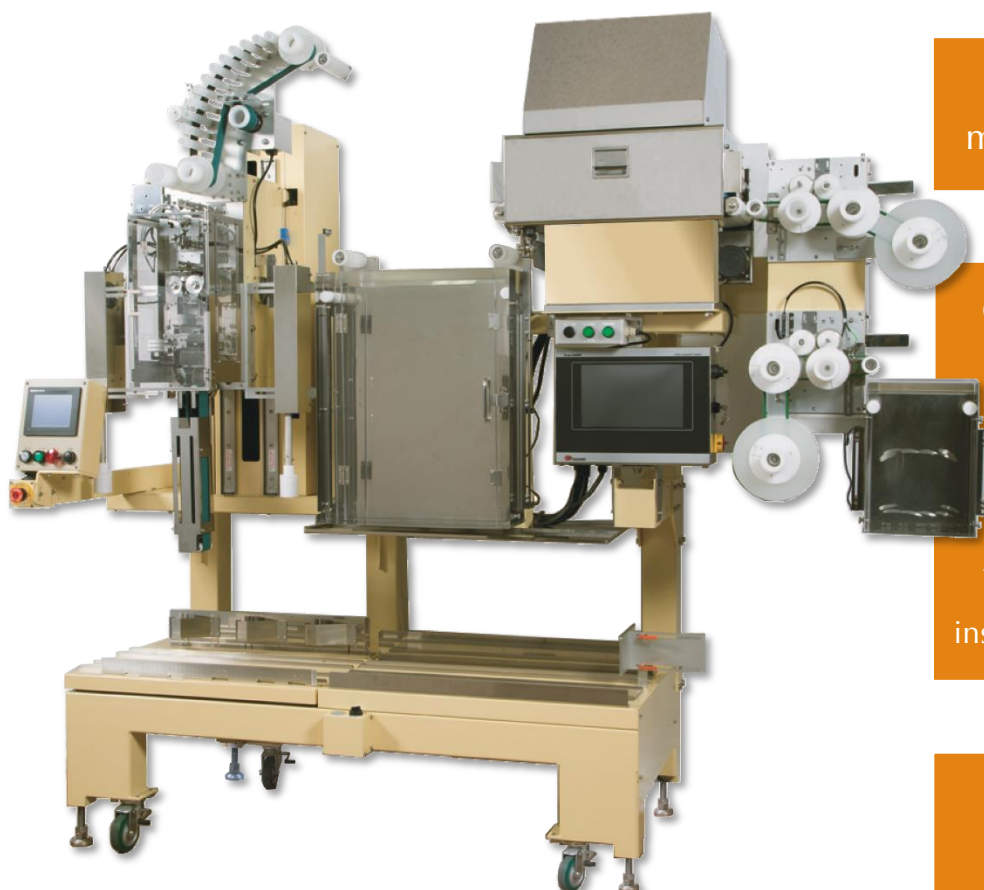

High-speed filling machines compatible.

Continuous pouches are correctly and quickly folded and stored.

Jam and foreign object inspecting with the inspection device function.

Easy operation with Touch-Panel.

Automatic Folding Device *X-ray Inspection Device* equipped

ORA-600TK FEATURES

Can be used for Powder, Liquid, Spices, Desiccants, Oxygen absorbers and more.

SCHEMATIC DIAGRAM

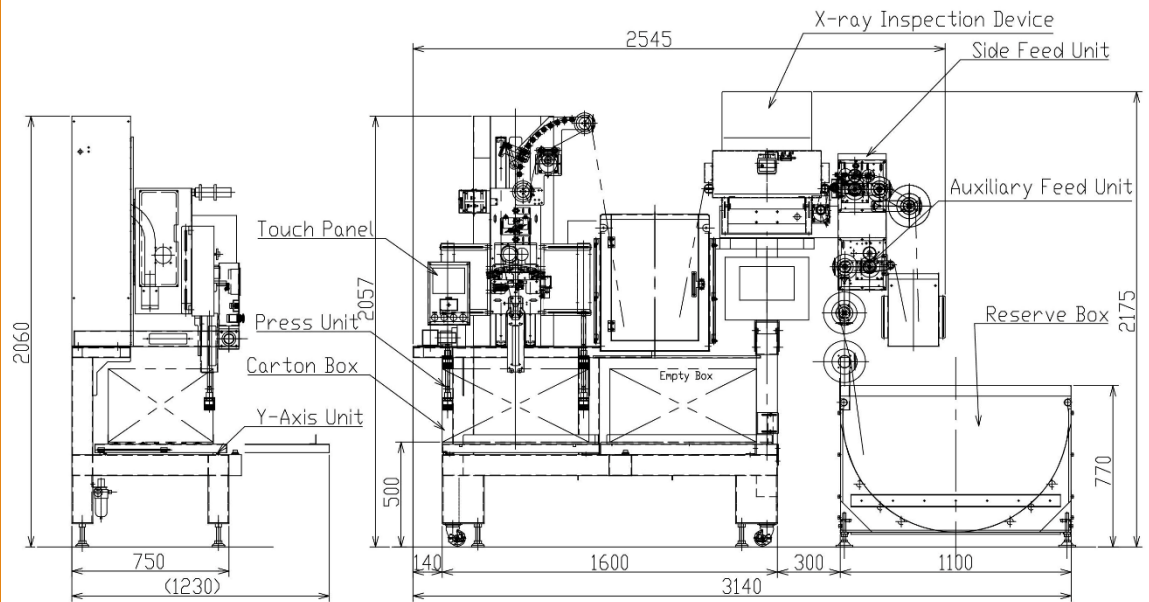

STANDARD SPECIFICATIONS

Storage Speed	60 m/min (When the box length 600mm)
Pouch Size	Width 30~100mm Length 30~100mm
Machine Dimensions	L2545mm × H2175mm × D770mm(1230mm)
Storage Box Size	L700mm × H350mm × D500mm
Reserve Box Size	L1100mm × H770mm × D270mm
Air Pressure Consumption	0.4~0.6MPa
Air Consumption	160Nl/min
Power Supply	Single phase AC 200V 50/60Hz 2.5KVA
Machine Weight	400kg

OPTIONAL DEVICES ARE AVAILABLE

※Automatic Folding Device oriented in the left direction is also available.

- Please do not hesitate to contact ASAHI KINZOKU for expert advice about our new **Automatic Folding Device**.
- Specifications and appearance are subject to change without notice. (because of improvements or updates).
- Additions or changes to the specifications can be arranged through consultation.



CAUTION

For Safe Use

- Read operation manual carefully before use to insure proper and correct operation
- Use the machine only with indicated electric current and voltage
- Be sure to ground the machine to prevent electrocution or short circuit.

Sales &
Manufacturing
Headquarters

 **ASAHI KINZOKU CO.,LTD**

505 Simomaruya-cho, Nishi-iru, Chiekoin-dori,
Shimodachiuri-dori, Kamigyo-ku, Kyoto city
602 - 8176 JAPAN
Tel +81-75-801-0154 Fax +81-75-842-1351
URL <http://www.akg.jp/kinzoku/>
E-mail asahi@akg.jp

Tokyo Sales Office

10-2 Miyamoto-cho, Ageo city, Saitama Prefecture
362-0036 JAPAN
Tel +81-48-771-0662 Fax +81-48-773-5937

Kyushu Sales Office

No. 206 Ichikura Building, 1-26, 2-chome, Hakata
station south, Hakata-ku, Fukuoka city
812-0016, JAPAN
Tel +81-92-471-5234 Fax +81-92-473-7150

■ Reference