

ASAHI KINZOKU Co.,Ltd

The pioneer of loading machine.

Automatic Folding Device

MODEL OR-22N

40m/min
Mid-Speed
Storage

Interlocks with a low/medium speed filling machine.

2 buttons only operation for normal use!

Fast and accurate pouch strip folding/boxing by interlocking with a low to medium speed filling machine.



Quick and simple operation with the touch-panel.

Easily operated with only 2 buttons for normal use.

Accurate folding and boxing with our improved swing duct.

30 different pouch data can be stored.
Simply switch between them as required.

OR-22N FEATURES

Can be used for Powder, Liquid, Spices, Desiccants, Oxygen absorbers and more. Fast and accurate folding and boxing of strips of pouches with connected filling machine.

SCHEMATIC DIAGRAM

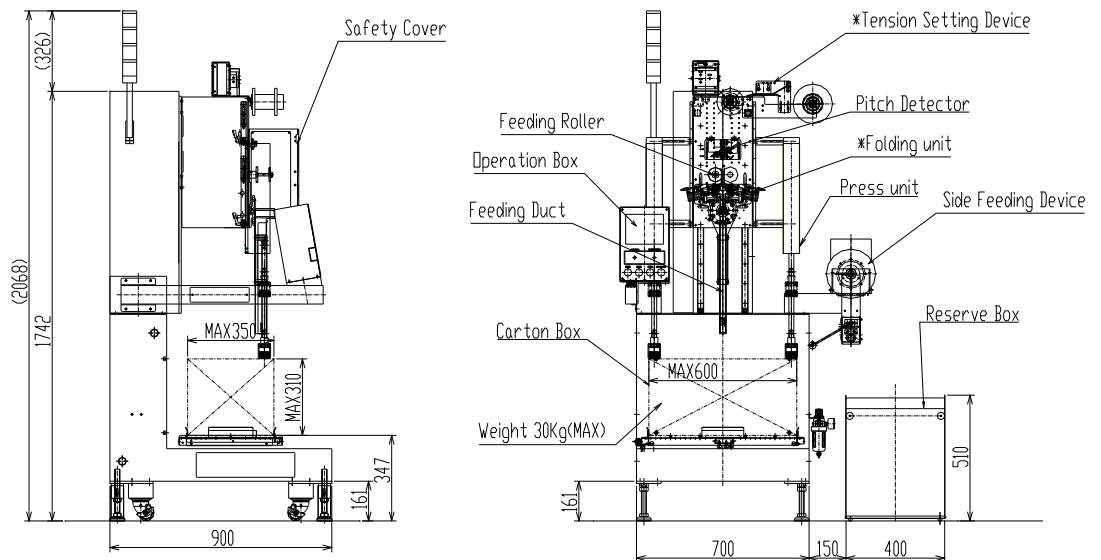

STANDARD SPECIFICATIONS

Storage Speed	40 m/min (When the box length is 580mm)
Pouch Sizes	Width 30~100mm Length 30~100mm
Machine Dimensions	L700mm × D900mm × H1742mm
Storage Box Size	L600mm × D350mm × H310mm
Air Pressure	0.4~0.6MPa
Air Consumption	80Nl/min
Power Supply	Single phase AC 200V 50/60Hz
Power Consumption	1.5KVA
Machine Weight	240kg

OPTIONAL DEVICES ARE AVAILABLE

●Cutter Unit ●Tension Setting Device ●Folding Unit etc.

※(Certain device options are not covered in standard model price)

※Automatic Folding Device oriented in the left direction is also available.

- Please do not hesitate to contact ASAHI KINZOKU for expert advice about our new **Automatic Folding Device**.
- Specifications and appearance are subject to change without notice. (because of improvements or updates).
- Additions or changes to the specifications can be arranged through consultation.



CAUTION

For Safe Use

- Read operation manual carefully before use to insure proper and correct operation
- Use the machine only with indicated electric current and voltage
- Be sure to ground the machine to prevent electrocution or short circuit.

Sales &
Manufacturing
Headquarters

 **ASAHI KINZOKU** CO.,LTD

505 Simomaruya-cho, Nishi-iru, Chiekoin-dori,
Shimodachiuri-dori, Kamigyo-ku, Kyoto city
602 - 8176 JAPAN
Tel +81-75-801-0154 Fax +81-75-842-1351
URL <http://www.akg.jp/kinzoku/>
E-mail asahi@akg.jp

Tokyo Sales Office

10-2 Miyamoto-cho, Ageo city, Saitama Prefecture
362-0036 JAPAN
Tel +81-48-771-0662 Fax +81-48-773-5937

Kyushu Sales Office

No. 206 Ichikura Building, 1-26, 2-chome, Hakata
station south, Hakata-ku, Fukuoka city
812-0016, JAPAN
Tel +81-92-471-5234 Fax +81-92-473-7150

■ Reference